

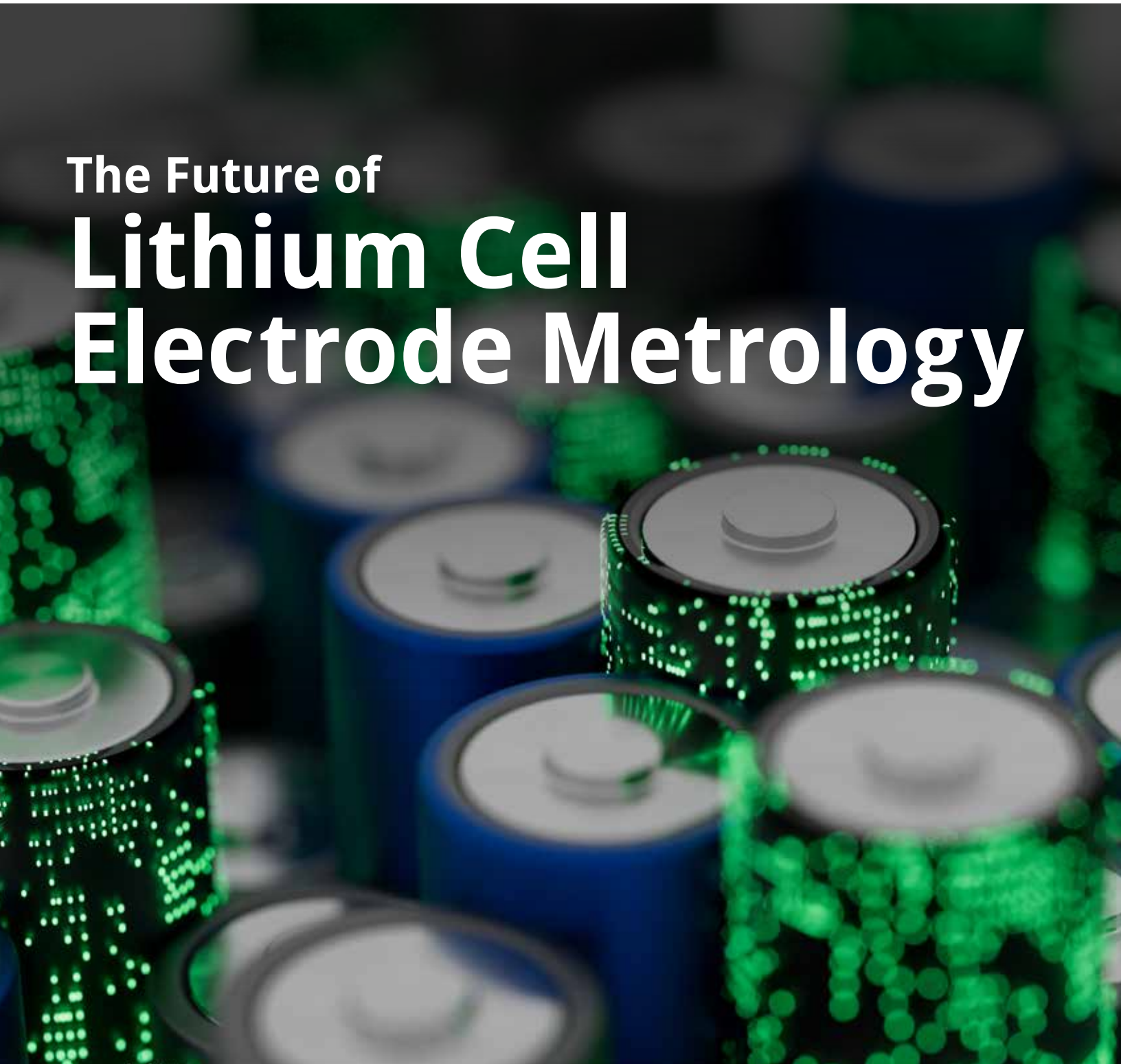

**Quad Plus<sup>®</sup>**

The Future of  
**Lithium Cell  
Electrode Metrology**



Connect with us



[www.quadplus.com](http://www.quadplus.com)

(815) 724-2323

# Overview Preface

QuadPlus is the global leader for dry-process electrode coating metrology. Our lithium cell process control solutions offer efficient marginal CAPEX/OPEX value.

The dynamic energy storage industry requires a fiducial engineering partner offering disruptive solutions consistent with fast evolving manufacture trends. Unlike "gauging-only" QCS vendors; QuadPlus offers an open, integrated system ecology enabling use of globally available sensing devices without bias to inconvenient proprietary sensors.

Quad Plus Applications can include:

- ✓ Dry process electrode coating & calendaring
- ✓ Wet Slurry electrode coating & calendaring
- ✓ Solid-state battery media pilot lines
- ✓ Green or brown field project management
- ✓ Separator media polymer or ceramics
- ✓ Sensing options: THz, mmWave, ultrasonic, x-ray, XRF, Beta, confocal laser, NIR, capacitance, hyperspectral IR imaging

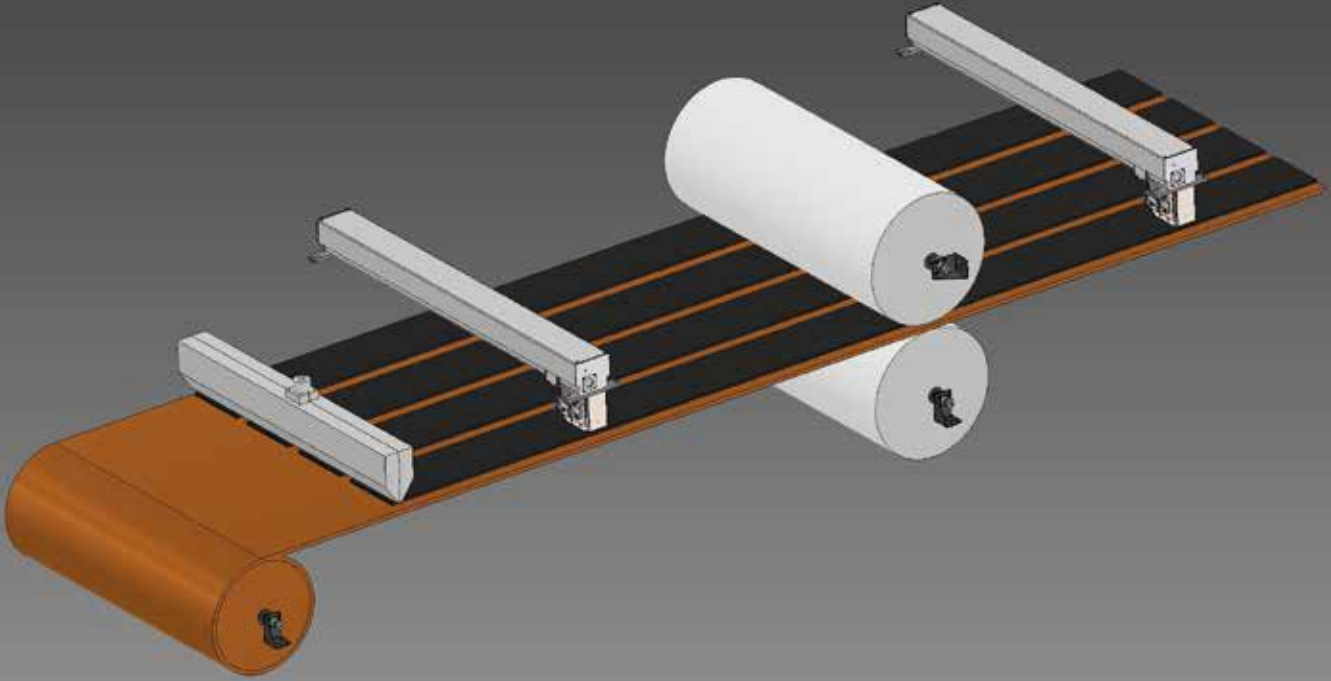

## Dry-Process

Dry-electrode processes are evolving but all offer inherent efficiencies as compared to wet-slurry manufacture. Enhanced electrode coating density/loading capacitance, fewer process phases, more compact gigafactory footprint and reduced environmental impact.

Volta Foundation reports these dry process economic benefits:

1. CAPEX reduced by 30-40%
2. Process footprint reduced by 65%, no solvent recovery, fewer process phases
3. OPEX reduced >30% by less energy consumption, no solvent recovery, reduced equipment and engineering support
4. Carbon CO2 footprint reduced by 60-70% may enable access to preferential tax and funding

Effective dry-process metrology requires discrete coating measurement of thickness, mass, density/loading. Typical compact factory footprint does not offer enough machine direction real estate to accommodate beta or X-ray differential deployment.

Moreover, any lithium electrode coating process has these end-use capacitance dependencies:

- ✓ Discrete electrode element coating uniformity
- ✓ Foil current-collector lay-flat tension "shape" uniformity
- ✓ Uniform coil-to-coil thickness, mass, density/loading

High precision metrology not only sustains compliance to coating specifications but enables higher cell wrap for improved jelly roll yields. A fully integrated data driven process eco-system can mitigate secondary value-add costs associated with cell test failure rates. Improving gigafactory yields, margins and cell safety.

QuadPlus deploys terahertz THz *time-of-flight* "ToF" reflection sensors on a multi-core PLC platform enabling multi-variable kilohertz 1000Hz data acquisition. This roll-2-roll "R2R" architecture yields improved measurement precision with fewer systemic elements and at reduced CAPEX/OPEX. Where applicable QuadPlus can offer beta-nucleonic, x-ray, laser and ultrasonic devices alone or as hybrid solutions.

The THz cross-direction profile can be used for electrode/foil flatness control when augmented with tension control sensors.

# Wet-slurry Electrode Coating?

Global lithium cell demand continues exponential gigafactory construction. Until dry-process and solid-state technologies mature, wet-slurry slot-die coating lines continue in step with cell demand.

Wet-slurry lines typically feature 5-6  $\beta$  or X-ray scanner/sensor stations. These sensors can only measure total mass [gsm]; to be effective they must operate in paired R2R differential mode. For example, Station #1 [S1] measures foil while station #2 [S2] measures foil and wet-slurry. Net coating weight depends on same-spot R2R alignment to enable array subtraction of [S2 - S1 = net coat gsm]. Assuming typical  $\pm 0.25\% 2\sigma$   $\beta$  sensor precision then differential measurement will be  $\sim \pm 0.58\% 2\sigma$  with each subsequent process phase having an additive  $\sqrt{\text{RMS}^2}$  error.

Terahertz mitigates these constraints:

- ✓ THz provides Time of Flight (ToF) coating measurement
  - Thickness/Caliper
  - Mass
  - Density/loading
- ✓ Depending upon coating line configuration; THz can reduce system complexity.
  - From 5-6 scanner/sensor stations to potential 2-4
  - Reduced cost single-side scanner design
  - R2R differential tracking not required
  - Improved net coat measurement precision

General advantages of terahertz ToF radar sensors when compared to a multiple  $\beta$  or X-ray sensor/scanner differential solution:

- ✓ Lower initial CAPEX with only one THz sensor / one scanning frame required
- ✓ Completely safe, does not require regulatory licensing or monitoring; Lower OPEX
- ✓  $\beta$  or X-ray are mass sensors that require Beer's Law calibration to thickness; ToF is a direct thickness measurement, but can also be deployed for basis weight &/or density
- ✓ Improved gauge R&R with ToF sensors (e.g., much higher precision, inherent same spot measurement of all layers, no R2R alignment required)
- ✓ Measurement pulse rate (100 or 1000Hz) application dependent
- ✓ Small measurement spot size  $\sim 2\text{mm}$
- ✓ Larger standoff from product (typically 50-150mm)
- ✓ Non-contact single-sided, reflection sensor – convenient low space profile
- ✓ THz is inherently immune to web flutter, vibration, dust, dirt, fumes
- ✓ Linear time calibration with optional NIST traceable standard for ISO9000 compliance.

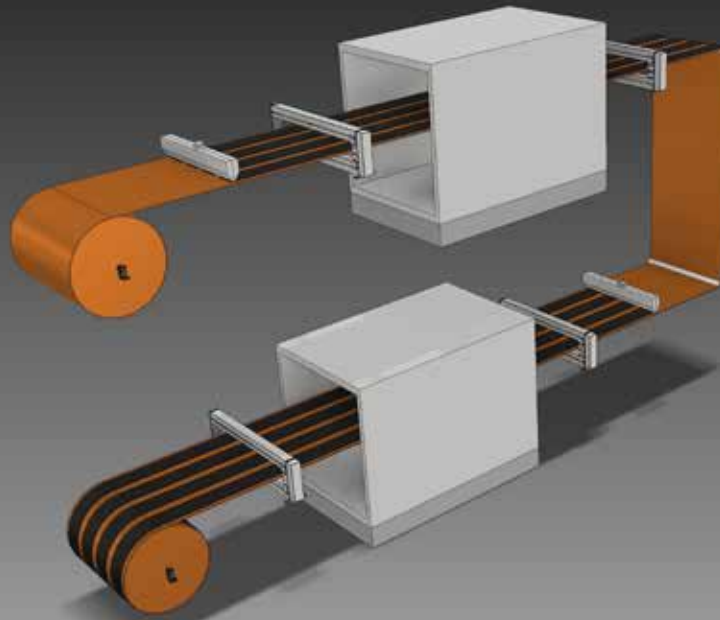

## Pilot-lines & Solid-state Cells

Quad Plus continues to partner with battery innovators as the global industry seeks ever more efficient energy storage solutions.

We offer small pilot scale systems customer designed for your needs. Our systems can often make lab deployment safer and less costly due to use of non-ionizing sensing physics.

## Application Considerations

Terahertz sensors are 100% human safe, non-nuclear, non-ionizing and widely applicable when factory floor metrology and process control require rugged industrial solutions.



# Quad Plus®

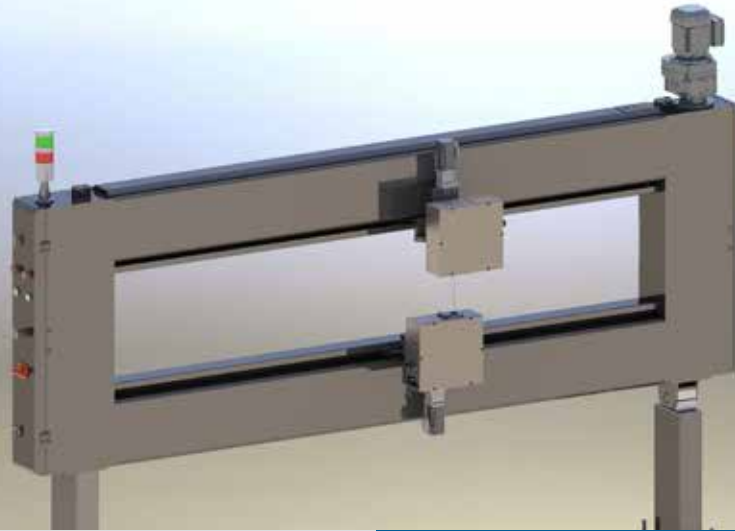

## Product Maintenance

We base our service offering on corrective and preventative maintenance that reduces downtime and helps you improve the process.

At Quad Plus, our support agreements offer

- ✓ System calibrations
- ✓ Preventative maintenance
- ✓ On-site repair

Complete package options are available with all travel and labor included.

## Education and Training

Our training, included with the sale of each system, helps you increase productivity by optimizing the use of your instruments and expanding the skills of your operators.

Training topics covered:

- ✓ Basic Operation
- ✓ Calibration
- ✓ Routine Maintenance
- ✓ Troubleshooting

## Headquarters:

**2200 Ellis Road  
New Lenox, IL 60451**

Connect with us



[www.quadplus.com](http://www.quadplus.com)

(815) 724-2323